

Vista da "A"

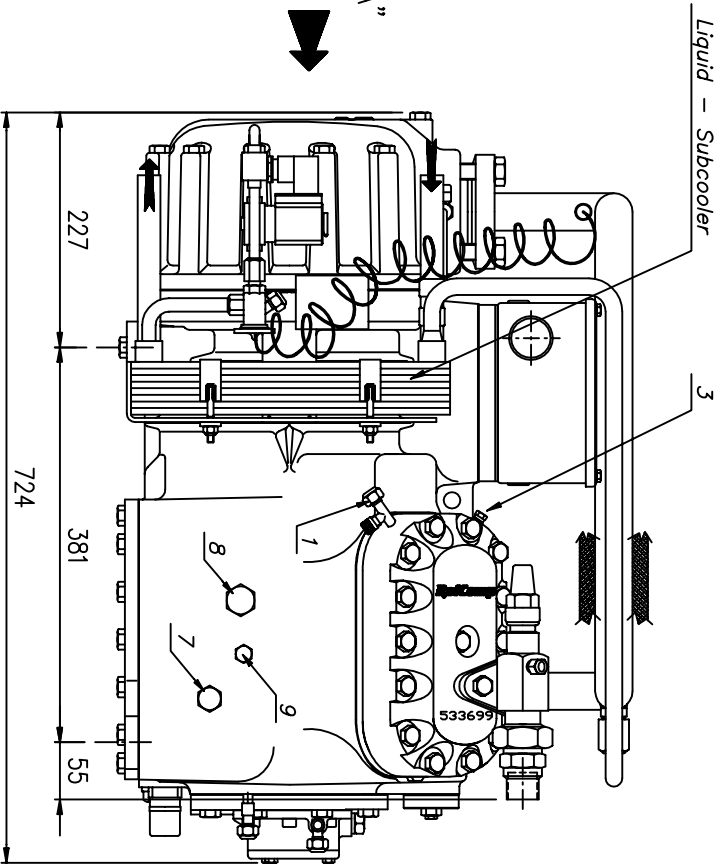

"A"

Legenda

KEY

- |   |   |
|---|---|
| 1 - Pressione intermedia 1/4" SAE-FLARE           | 1 - Intermediate pressure 1/4" SAE-FLARE  |
| 2 - Bassa pressione 1/8" NPT                      | 2 - Low pressure 1/8" NPT                 |
| 3 - Alta pressione 1/4" SAE-FLARE                 | 3 - High pressure 1/4" SAE-FLARE          |
| 4 - Resistenza carter                             | 4 - Crankcase header                      |
| 5 - Tappo filtro olio                             | 5 - Oil strainer plug                     |
| 6 - Scarico olio                                  | 6 - Oil drain 1/4" NPT                    |
| 7 - Equalizzazione olio (operazione in parallelo) | 7 - Oil equalization (parallel operation) |
| 8 - Equalizzazione pressione (operaz. parallelo)  | 8 - Gas equalization (parallel operation) |
| 9 - Carica olio 1/4" NPT (dalla parte opposta)    | 9 - Oil charging 1/4" NPT (opposite side) |
| 10 - Alta pressione olio 1/4" SAE-FLARE           | 10 - Oil high pressure 1/4" SAE-FLARE     |
| 11 - Bassa pressione olio 1/4" SAE-FLARE          | 11 - Oil low pressure 1/4" SAE-FLARE      |
| 12 - Bassa ritorno olio separatore 1/8" NPT       | 12 - Oil return from separator 1/8" NPT   |

|   |           |             |           |
|---|-----------|-------------|-----------|
| ESP.  | MODIFICHE | DATA        | FIRMA     |
| MATERIALE: ---  |           |             |           |
| RATTAMENTO TERMICO: ---   |           |             |           |
| SOSTITUISCE: ---  | ESP. ---  |             |           |
| SOSTITUITO DA: ---  | ESP. ---  |             |           |
| FIRMA   | DISEGNATO | CONTROLLATO | APPROVATO |
| DATA  | Portinari |             |           |
| SCALE: 1:5  |           |             |           |
| ALTRA: ---  |           |             |           |
| <p><b>Reflcomp</b><br/>         REFRIGERANT COMPRESSORS<br/>         Lonigo (Verona) Italy</p> <p>DENOMINAZIONE:<br/> <b>INGOMBRI DOPPIO STADIO "SB4 cil."</b></p> <p>MODELLO: "SB4 cil."</p> <p>TAVOLA:<br/>         1/1</p> <p>CODICE:<br/> <b>MP1005</b> ESP. 00</p> |           |             |           |