

*134-XS and 134-S series compressors**Capacity control**(EA-03-04-E)*

3	CAPACITY CONTROL	2
3.1	134-S SERIES	2
3.1.1	<i>Operating principle and oil control circuit</i>	2
3.1.2	<i>Step capacity control</i>	2
3.1.3	<i>Control sequence: step configuration</i>	6
3.1.4	<i>Infinity capacity control: stepless configuration</i>	9
3.1.5	<i>Control sequence : stepless configuration</i>	10
3.2	134-XS SERIES	10
3.2.1	<i>L1 configuration: working principle and control circuit</i>	11
3.2.2	<i>L2 configuration</i>	13
3.2.3	CONTROL SEQUENCE: STEP CONFIGURATION	16
3.3	PROCEDURE FOR STARTING AND STOPPING THE COMPRESSOR	17
3.4	OPERATING LIMITS AT PART LOAD	18
3.5	MANAGING THE STEPLESS PARTIAL LOAD	18

3 Capacity control

The RefComp screw compressors can operate both at full load and part load. In particular for the 134-XS series (models: 40-50-60 Hp) 'step' L2 configuration with 3 steps (50-75 and 100% load) is available, while for the 134-S series both the 'step' L4 configuration with 4 steps (minimum-50-75 and 100% load) and the 'stepless' LZ configuration (continuous variation of the load, from the minimum step to 100%, or from 50 to 100%) are available. The two series of compressors are described separately below.

3.1 134-S Series

3.1.1 Operating principle and oil control circuit

The cylindrical chambers that house the screw rotors are fitted with a longitudinal opening (longitudinal port) at the bottom, through which the connection to the suction side is adjusted by the position of the slide valve (1), see Figure 3-A on the following page. When the valve completely closes the opening, the effective compression length is maximum and coincides with the entire length of the rotors; when, on the other hand, the valve moves towards the discharge and the opening expands longitudinally, the effective working length of the rotors is reduced and as a consequence a smaller quantity of gas is processed. As a result, adjusting the volume taken in by the rotors make it possible to control the mass flow processed and definitely the cooling capacity generated by the compressor.

The slide valve (1) is controlled by a hydraulic cylinder activated by the oil pressure. The oil circuit that manages the capacity control features three normally-closed solenoid valves (14 – 15 – 16), see Figure 3-A and two different plates (4), used to install the step and stepless configurations.

The following paragraphs describe the operation of the oil circuit in the two configurations, while chapter EA-15: '*Capacity control conversion*' shows the required operating instructions to change from one configuration to the other.

3.1.2 Step capacity control

The slide valve is controlled by a hydraulic piston that can have four distinct positions, corresponding to the capacity steps: 100 - 75 - 50% - minimum step (note: the effective capacity steps may differ from the rated values, according to the normal operating conditions and from compressor to compressor).

The plate (4) allows the solenoid valve (16) to control the flow of oil from the hole corresponding to the 75% step to the suction side (section of the circuit marked by numbers 1 and 2). The oil enters the slide valve hydraulic control cylinder continuously (section of the circuit marked by numbers 3 and 4), thanks to a bypass made in the plate (4), see Picture 3-A.

Switching from one configuration to the other is possible by replacing the plate (4), see chapter EA-15 "*Capacity control conversion*".

Below is a brief description of the operation of the oil circuit in the four compressor capacity steps.

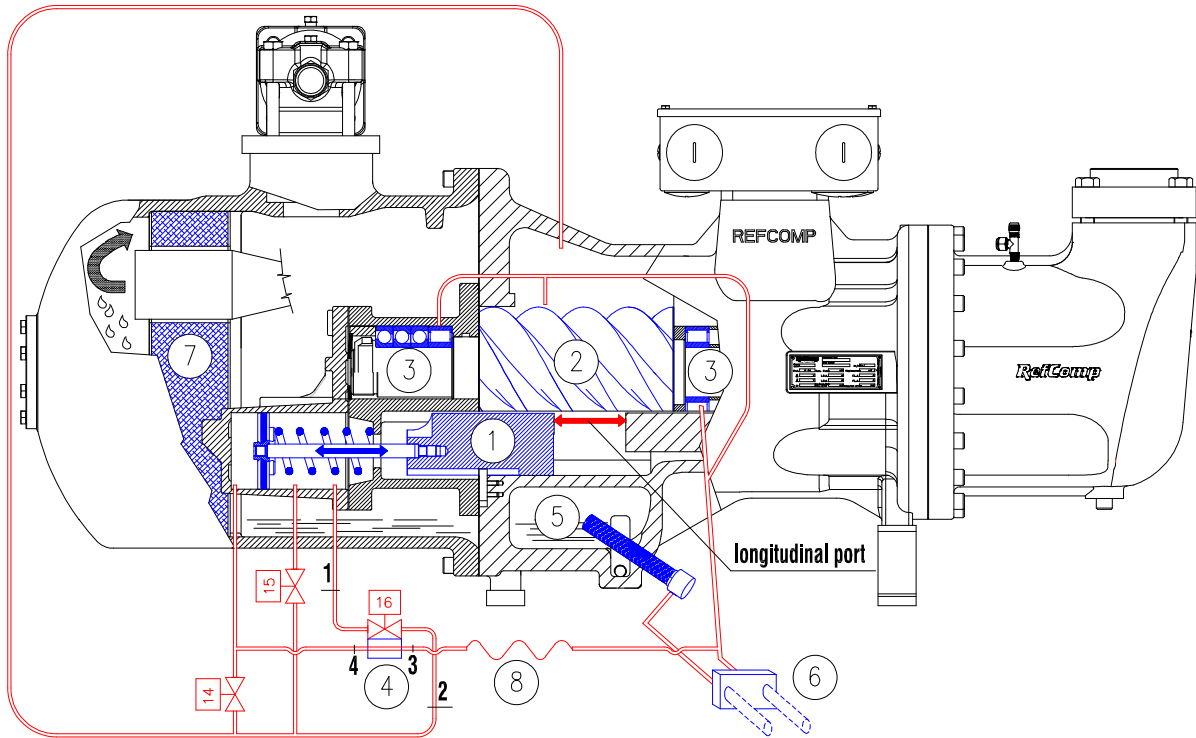

Picture 3-A: step capacity control oil circuit for 134-S series;

- 14, 15, 16: capacity control solenoid valves;
- 1: capacity control (134-S series) slide valve and operation piston;
- 4: step-stepless switch plate;
- 8: capillary tube (internal to the compressor);

✓ **MINIMUM CAPACITY STEP (COMPRESSOR STEP FOR START UP AND STOP)**

Picture 3-B shows how the oil runs inside the control circuit. At the minimum step the solenoid valve 14 is opened, while the valves 15 and 16 are closed. Therefore the oil, coming from the oil reservoir, flows through the opened port to the suction side, not pressurising the control cylinder. Consequently the piston is pushed to the end stroke, the longitudinal port is completely opened on the suction side and the length along which the rotors are working is the shortest.

	<p>Warning! Concerning the step capacity control mode (4 steps), the minimum capacity step can be used only to start and stop the compressor; it cannot be used to give cooling power.</p>
--	---

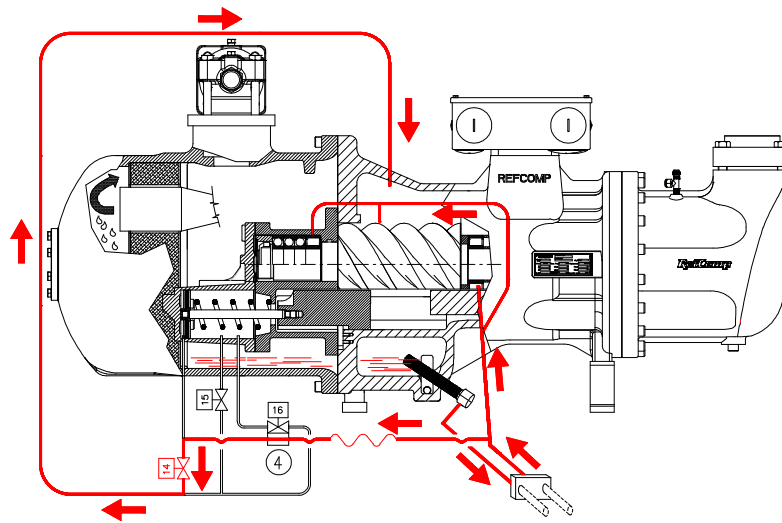

Picture 3-B: capacity control at minimum step;

✓ **50% CAPACITY**

With reference to Picture 3-C at 50% capacity, the solenoid valve 15 is open while the valves 16 and 14 are closed; the oil enters the cylinder (through the 1st hole on the left) and drives the piston to the position corresponding to the 2nd hole, where the oil flows to the suction side. The slide valve also moves and partially closes the longitudinal opening, thus increasing the effective working length of the rotors.

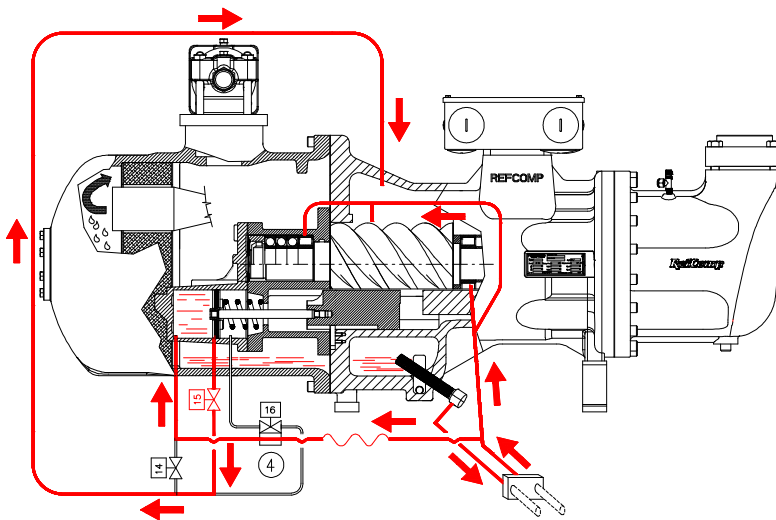

Picture 3-C: capacity control at 50%;

✓ 75% CAPACITY

At 75 % capacity, see Picture 3-D, the situation is similar to the previous one, but now the solenoid valve 16 is open while the valves 15 and 14 are closed; the control piston is thus positioned corresponding to the 3rd hole, the slide valve closes the opening further and increases the working length of the rotors.

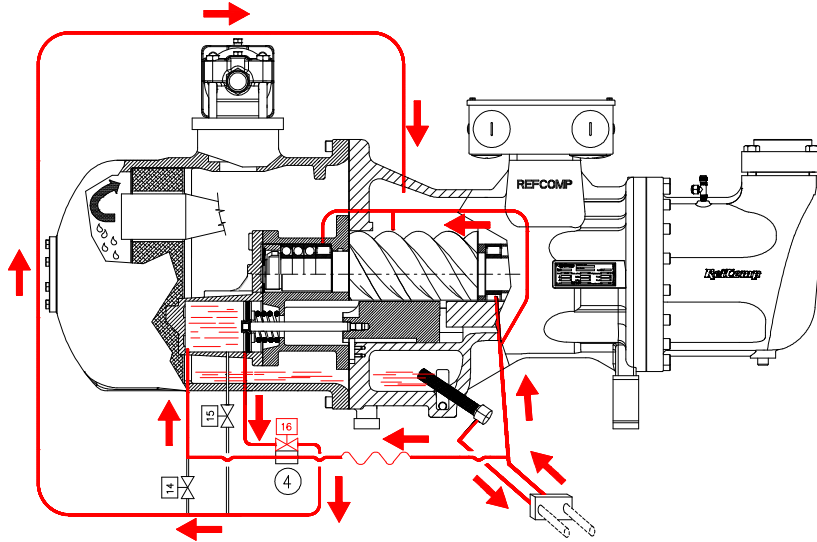

Picture 3-D: capacity control at 75%;

✓ 100% CAPACITY

At 100% capacity, see Picture 3-E, all the solenoid valves are closed; the oil can no longer leave the cylinder and pushes the piston to the limit on the right side and the slide valve completely closes the longitudinal opening, meaning that compression can occur along the entire length of the rotors.

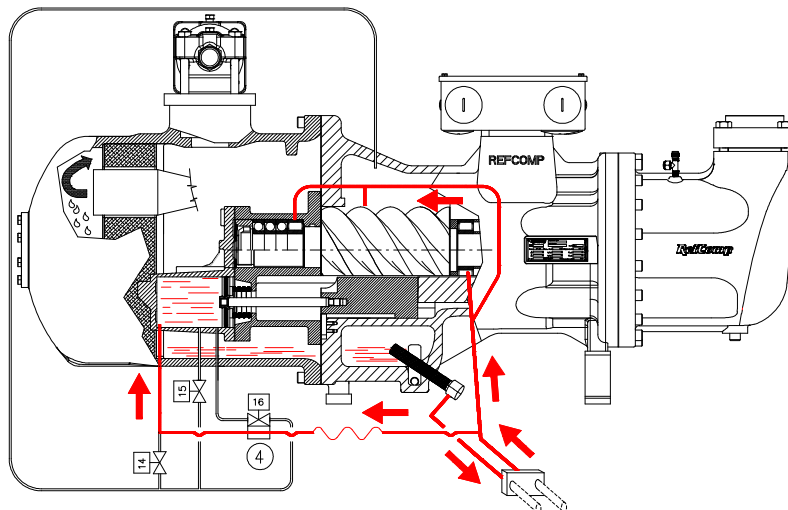

Picture 3-E: full load: 100%;

3.1.3 Control sequence: step configuration

The oil flow is controlled by the three solenoid valves, normally closed, positioned on the top of the compressor casing, see Picture 3F) (134-S-71.....134-S-220) and Picture 3G) (134-S-240...134-S-300) They are energised according to the logic shown in Table 3-A (134-S-71.....134-S-220) and in Table 3-B (134-S-71.....134-S-220).

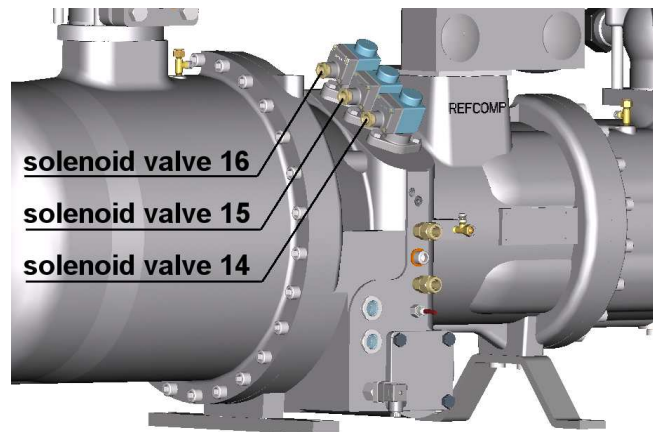

Picture 3-F: solenoid valve position for capacity control on 134-S series compressors (134-S-71....134-S-220);

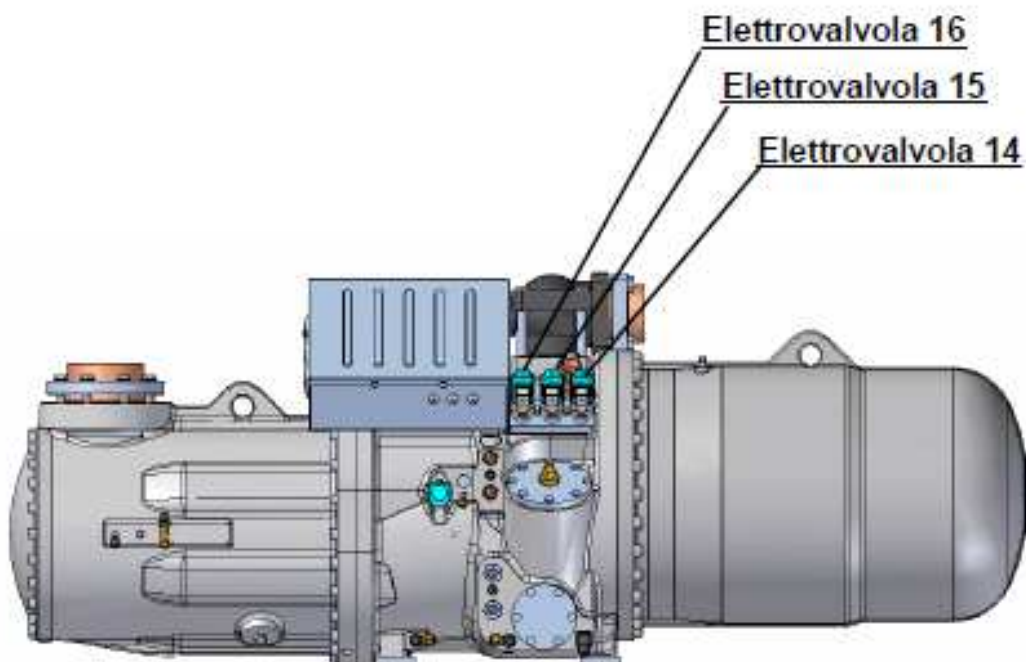

Picture 3-G: solenoid valve position for capacity control on 134-S series compressors (134-S-240....134-S-300);

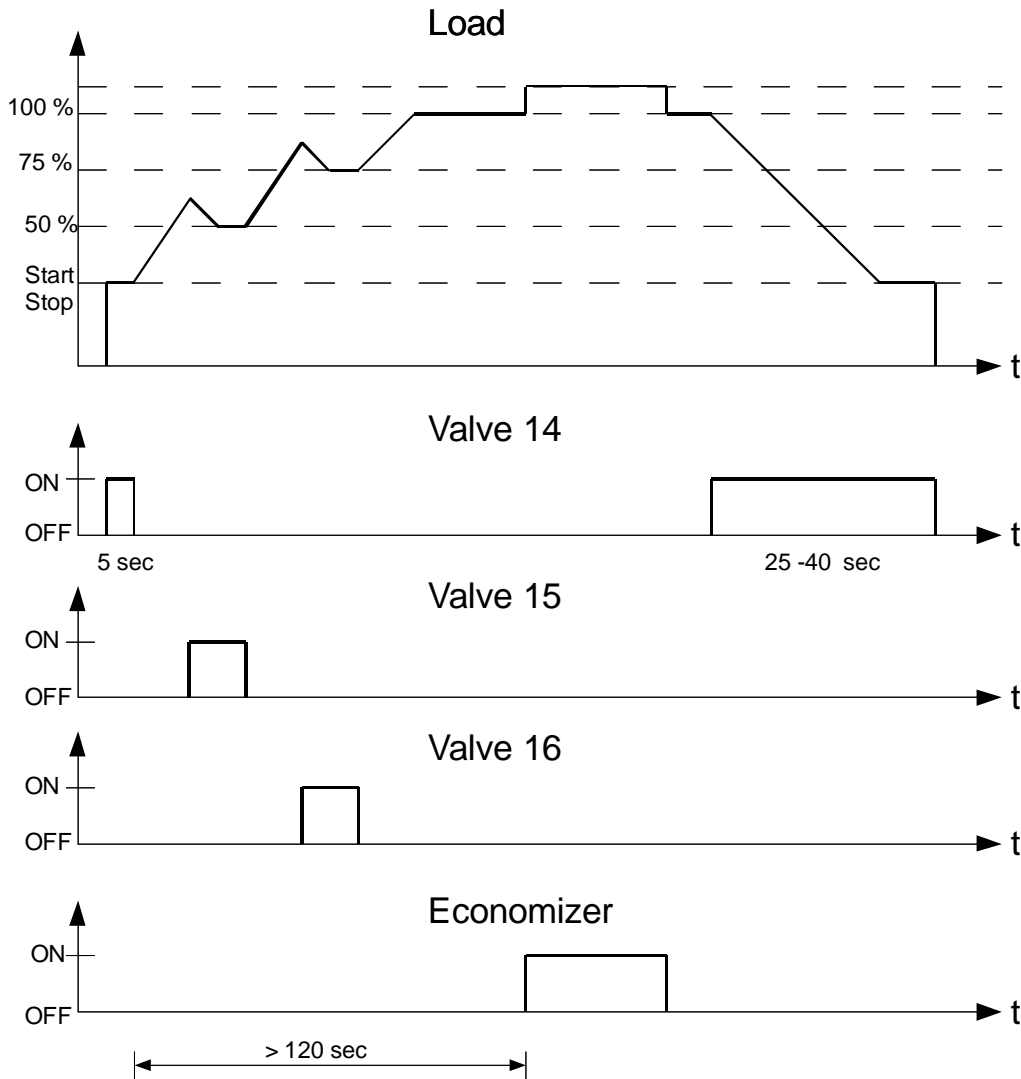

Capacity Step	SOLENOID VALVE		
	16	15	14
100%	Off	Off	Off
75%	On	Off	Off
50%	Off	On	Off
Start/Stop	Off	Off	On

“Off”= not excited solenoid

“On”= excited solenoid

Table 3-A: operating logic of the solenoid valves for step capacity control

3.1.4 Infinity capacity control: stepless

Infinite capacity control is recommended whenever the cooling capacity of the system has to be controlled with a high degree of precision, while it is not very useful in systems featuring high inertia, where step capacity control is more suitable.

In this configuration, the plate (4) is configured so that the solenoid valve (16) controls the flow of oil entering the hydraulic cylinder that operates the slide valve (section of the circuit marked by numbers 3 and 4 in Picture 3A). The 75% step control function is disabled, and for this reason the section of circuit marked by numbers 1 and 2 in will not be shown in Picture 3-H below.

The cooling capacity is therefore controlled by using the normally-closed solenoid valves (14), (15) and (16), with the following logic:

- ✓ (16): fill the hydraulic cylinder for increasing the cooling capacity required by the users;
- ✓ (14), (15): empty the hydraulic cylinder, until the minimum step or 50%, to decrease the cooling capacity required by the users.

This brings about continuous control of the flow processed by the compressor, from the minimum value to the maximum value. For details on how to replace the plate (4) and convert the configuration from the step to stepless, see chapter EA-15 '[Capacity control conversion](#)'.

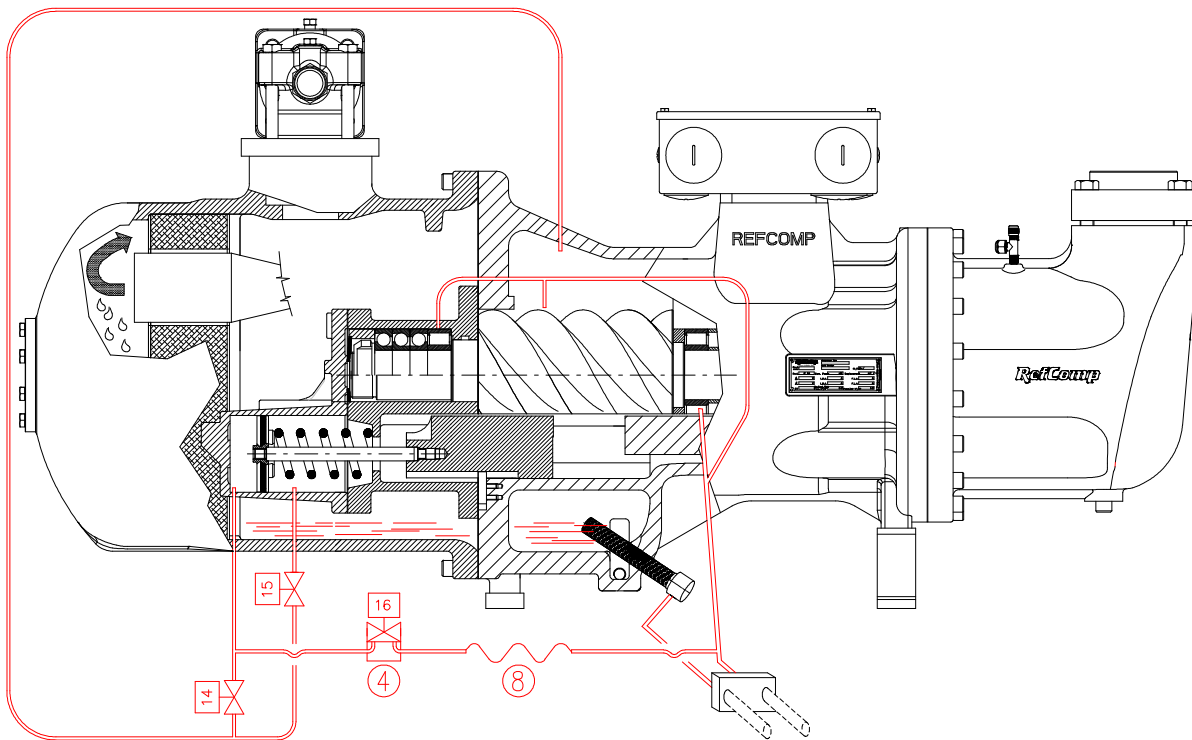

Picture 3-H: infinite capacity control oil circuit (step less configuration) for 134-S Series compressors;

3.1.5 Control sequence: stepless configuration

The cooling capacity control is obtained using the solenoid valve (14), (15) and (16) those have to be energised following the scheme of Picture 3-I and table 3-B

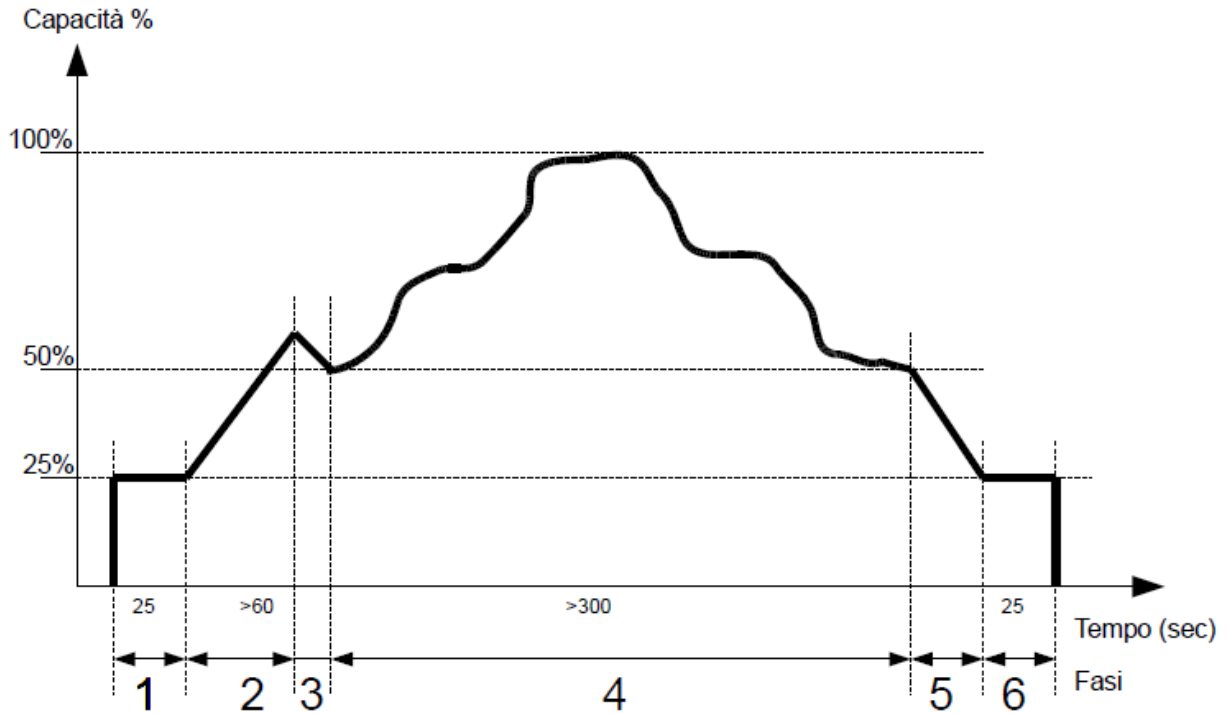

Picture 3-I Scheme of logic of functioning of solenoid valves

INFINITY CONTROL 100÷50%				
Phase	Regolation	SOLENOID VALVE		
		14	15	16
1	Start	ON	OFF	OFF
2	Load > 50%	OFF	OFF	ON
3	Unload down to 50 %	OFF	ON	OFF
4	Modulation	OFF	ON/OFF	ON/OFF
5	Unload down to 25%	ON	OFF	OFF
6	Stop	ON	OFF	OFF

“Off”= solenoid valve non excited

“On”= solenoid valve excited

Table 3-B : logic of functioning

	<p>Warning!</p> <p>The working at partial load condition is allowed according to the application limits reported in the chapter EA-10: “<i>Application limit</i>”.</p> <p>Particularly, the compressor can work at the minimum capacity step only during the start up phase, the stop phase (see paragraph 3.3) and in any case for short period of time (see previous page).</p> <p>At any rate the part load operation requires specific actions to prevent:</p> <ul style="list-style-type: none">✓ The insufficient return of oil due to the reduced speed of the gas;✓ Higher temperatures on the discharge side, caused by the compression lower efficiency and by the lower refrigerant flow mass;✓ An overheating of the electrical motor that might occur whenever the tension value is out of the given range. <p>Thorough and extensive testing is recommended.</p>
---	---

3.2 134-XS series

For the 134-XS series the capacity control is now obtained by the new configuration L2, while in the past L1 was the capacity control system. The difference between these two configurations is basically the number of the capacity steps. As a matter of fact for:

- ✓ L1 configuration: one only solenoid valve and two capacity steps (50-100%);
- ✓ L2 configuration: two solenoid valves and three capacity steps (50-75-100%);

Hereinafter are described the working principle of the two different configurations.

3.2.1 L1 configuration: working principle and control circuit

With reference to Picture 3-J, the capacity is controlled by the pistons (1) which, exploiting the high or low pressure through just one solenoid valve (the number 20), open or close the internal passageways (2). These passageways bypass part of the fluid compressed by the rotors (50%) directly to the suction side. Consequently only 50% of the mass flow reaches the discharge side. Bypassing part of the mass flow processed by the compressor thus controls the cooling capacity.

Hereinafter the 50% and 100% load capacity steps are considered.

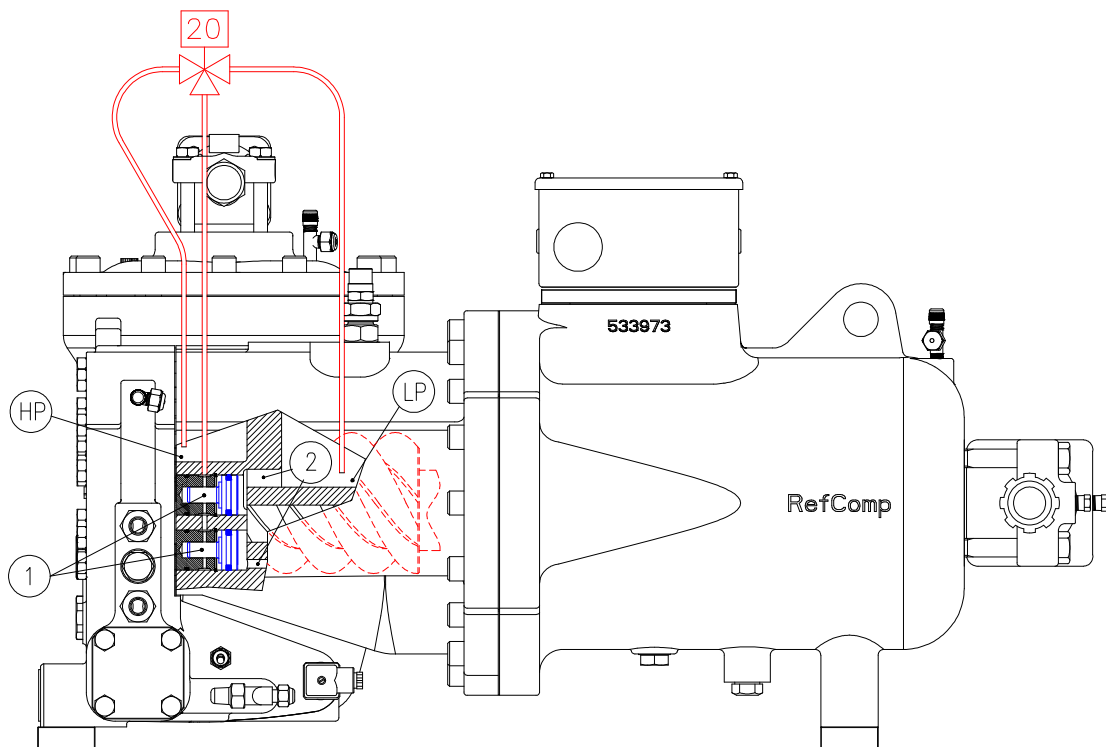

Picture 3-J: working principle for the capacity control on 134-XS series compressors: L1 configuration;

- 20: solenoid valve for controlling the 50 and 100% capacity steps;**
- 1: pistons activated by the refrigerant-oil mixture to bypass the mass flow to the suction side;**
- 2: passageways to bypass the refrigerant to the suction side;**
- HP: high pressure (discharge side);**
- LP: low pressure (suction side);**

✓ **50% CAPACITY**

With reference to Picture 3-K, the solenoid valve (20) is energised, making the cylindrical chambers, that house the pistons, communicate into the low pressure suction side. Due to the higher pressure in the compression chambers (intermediate pressure between suction and discharge) the pistons move and open the passageways that bypass 50% of the flow to the suction side (the red arrows in the picture show the movement). This ensures operation at part load.

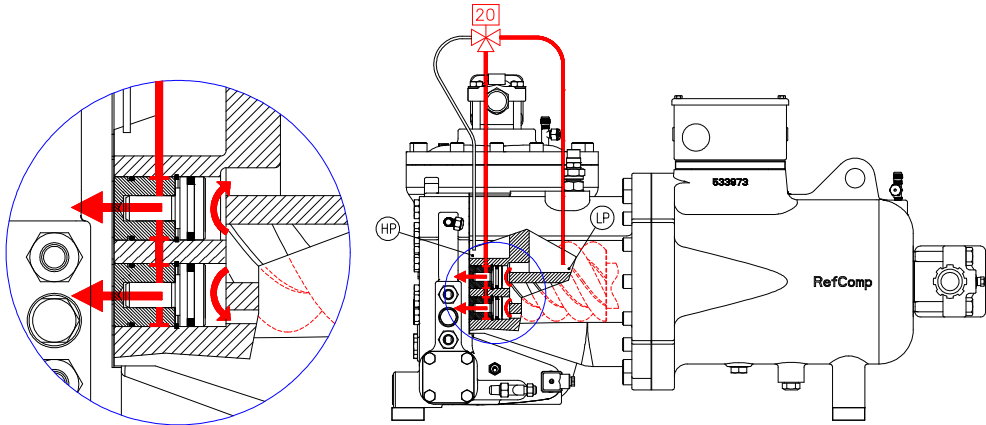

**Picture 3-K: 50% capacity control: L1 configuration;
LP: low pressure;**

✓ **100% CAPACITY**

In this case and with reference to Picture 3-L, the solenoid valve (20) is not energised and as a consequence the cylindrical chambers communicate into the high pressure discharge side. Due to the higher pressure here than the intermediate pressure in the compression chamber, the pistons move (the red arrows show the movement) closing the passageways that bypass the fluid. The entire flow of refrigerant processed by the compressor thus reaches the discharge, meaning operation at 100% load.

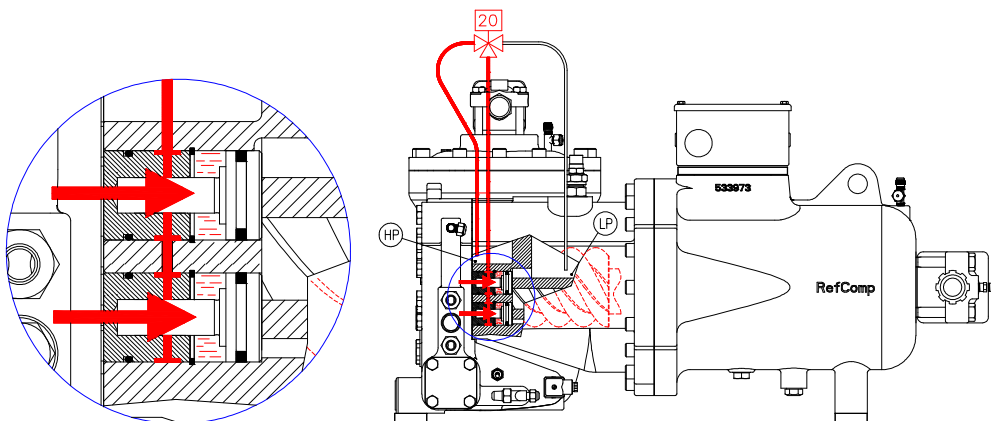

**Picture 3-L: 100% capacity control: L1 configuration;
HP: high pressure;**

3.2.2 L2 configuration: working principle and control circuit

With reference to Picture 3-M, the working principle is that already described in the previous paragraph. But now there are two solenoid valves instead of one. They are marked by the numbers 20 and 21, and each of them controls a single piston (1). So now the two pistons are independent and each one allows the by-pass of the 25% of the refrigerant mass flow. Via the solenoid valves is then possible to assure either the 75% or the 50% of the cooling capacity.

Hereinafter are described the three possible capacity steps: 50%, 75% and 100%.

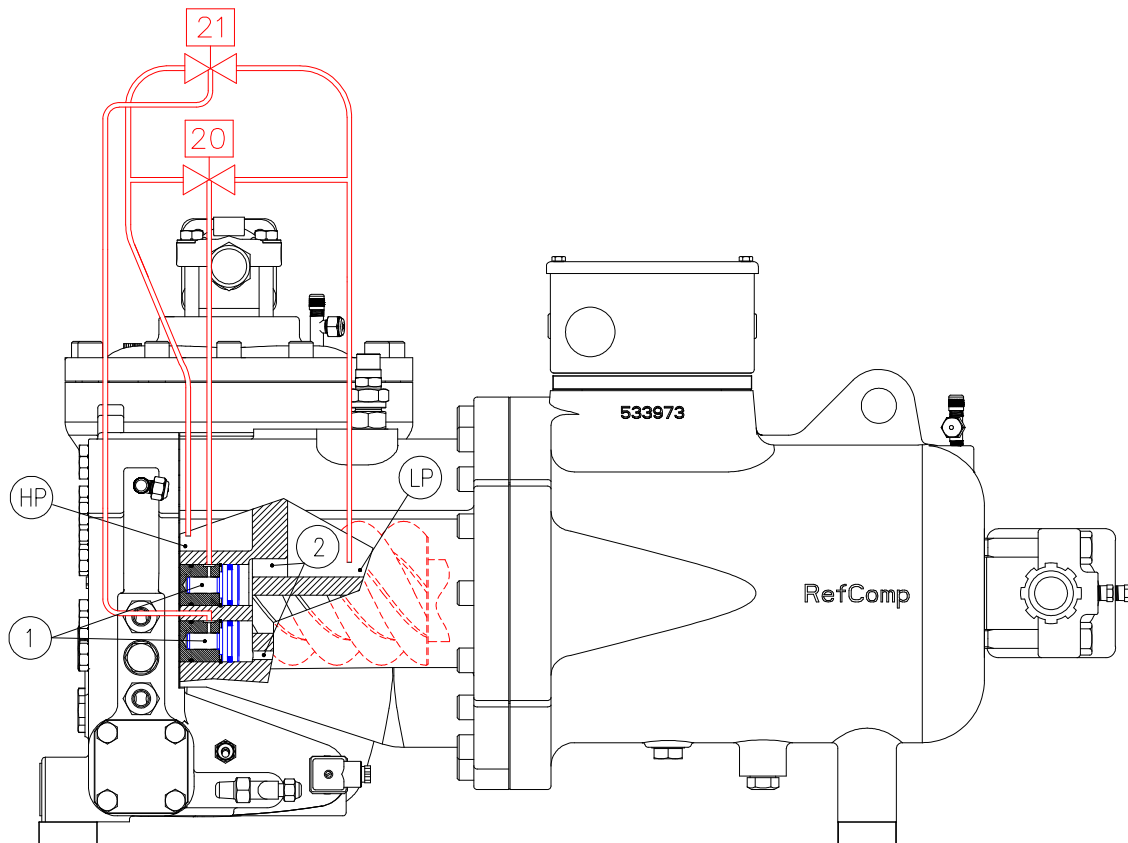

Picture 3-M: working principle for the capacity control on 134-XS series compressors: L2 configuration;

- 20, 21: solenoid valves for controlling the 50, 75 and 100% capacity steps;**
- 1: pistons activated by the refrigerant-oil mixture to bypass the mass flow to the suction side;**
- 2: passageways to bypass the refrigerant to the suction side;**
- HP: high pressure discharge;**
- LP: low pressure suction;**

✓ **50% CAPACITY**

With reference to Picture 3-N, both the solenoid valves (20) and (21) are energised, making the cylindrical chambers that house the pistons communicate into the low pressure suction side. The pistons, then, due to the higher pressure in the compression chamber (intermediate pressure between suction and discharge) move (the red arrows show the movement), opening both the passageways that bypass 50% of the flow to the suction side. This ensures operation at 50% part load.

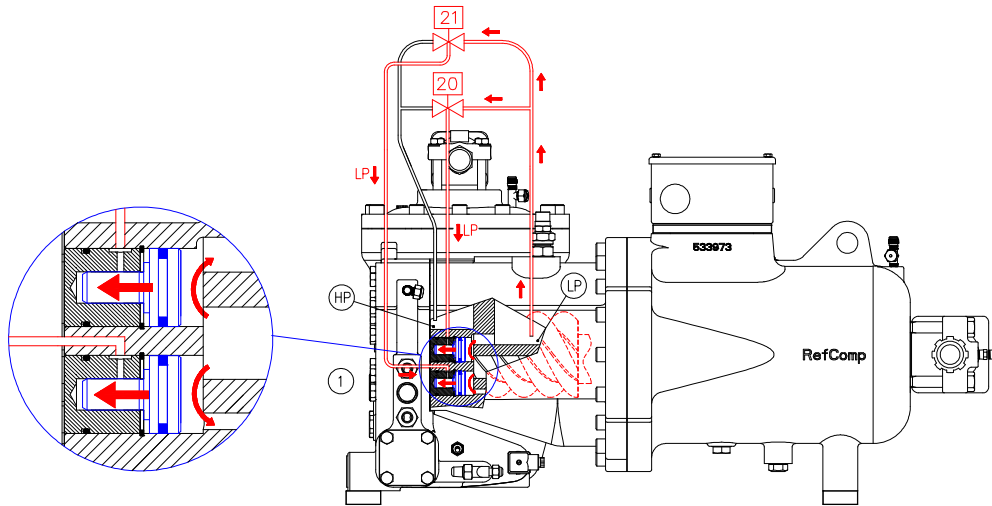

**Picture 3-N: 50% capacity control: L2 configuration;
LP: low pressure;**

✓ **75% CAPACITY**

By looking at Picture 3-O, the solenoid valve (21) remains energised so that the related lower piston opens the passageway for the by-pass of the 25% of the flow to the suction side. The solenoid valve (20) instead is de-energised and its related upper piston closes the other by-pass passageway (the red arrows show the movement of the pistons). That way only one piston assures the mass flow by-pass and consequently the discharge mass flow is 75% of the total one.

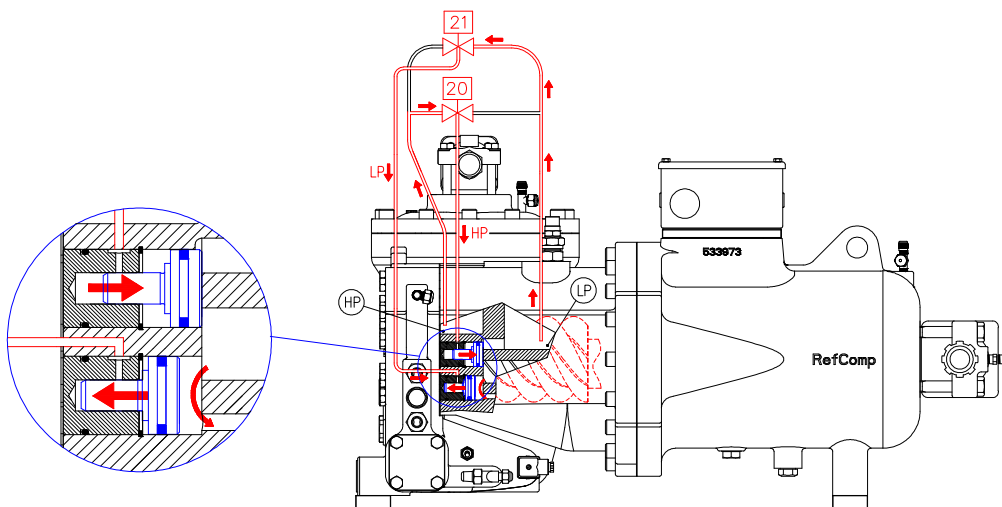

**Picture 3-O: 75% capacity control: L2 configuration;
LP: low pressure;
HP: high pressure;**

✓ 100% CAPACITY

With reference to Picture 3-P, both the solenoid valves (20) and (21) are not energised and as a consequence the cylindrical chambers communicate into the high pressure discharge side. Due to the higher pressure here than the intermediate pressure in the compression chamber, the pistons move (the red arrows show the movement) closing both the passageways that bypass the fluid. The entire flow of refrigerant processed by the compressor thus reaches the discharge, meaning operation at 100% load.

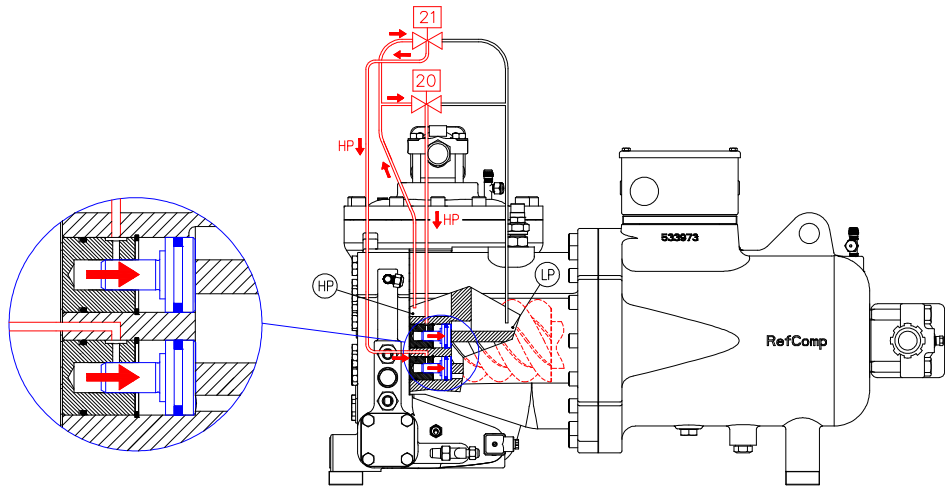

**Picture 3-P: 100% capacity control: L2 configuration;
HP: high pressure;**

3.2.3 Control sequence: step configuration

The flow of the oil is controlled by the solenoid valves (20) and (21) which are located on the top of the compressor casing, see Picture 3-Q. In Table 3-C is shown how to energise the solenoid valves.

L1 Configuration

L2 Configuration

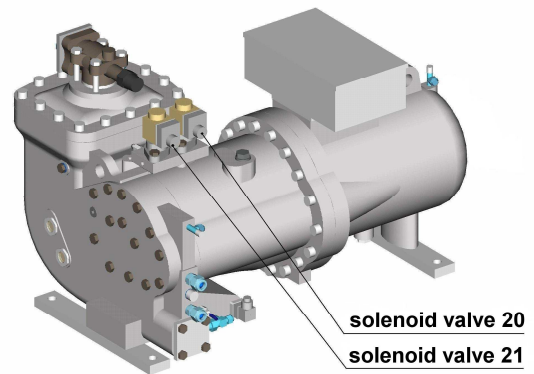
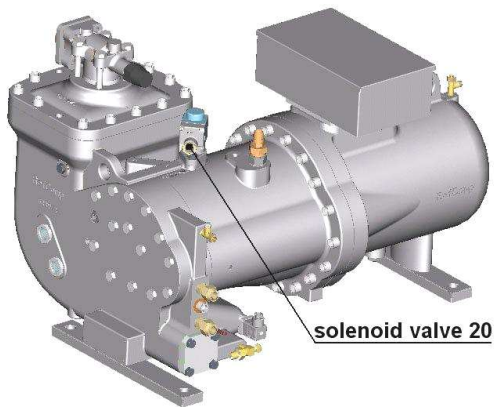

Picture 3-Q: position of the solenoid valves (20) and (21) for capacity control in the series 134-XS compressors;

Capacity	L1	L2	
	Solenoid valve	Solenoid valves	
	20	20	21
100%	OFF	OFF	OFF
75%	-	OFF	ON
50%	ON	ON	ON

OFF = solenoid not energised;
ON = solenoid energised;

Table 3-C: operating logic of the solenoid valves for step capacity control;

3.3 Procedure for starting and stopping the compressor

To limit the peak current when starting, the electric motors are started in the part-winding configuration, or alternatively with the windings connected in the star configuration (see chapter EA-05: 'Electrical devices'). This, however, means also a drop in the starting torque, and as a result the resisting torque needs to be reduced in order to start the compressor without excessively overloading the electric motor. For this purpose, Refcomp recommends to start the compressors at the minimum capacity step, see Picture 3-R.

As regards the models of the series 134-S, distinction needs to be made between the step and the stepless configuration.

- In the **configuration with 4 steps** the slide valve automatically returns to the position of minimum capacity after the compressor stops. In fact due to the pressure difference the oil can flow out of the cylinder to the crankcase through the pipe marked by numbers 3 and 4, (Picture 3-A).
- In the **infinite configuration**, on the other hand, this pipe is closed by the solenoid valve (16), which is normally closed. Consequently, unless the solenoid valve (14) is energised before stopping, the oil cannot flow out of the cylinder and as a result the compressor is not discharged.

For this reason, so as to stop and re-start the compressor at the minimum capacity step, see Picture 3-R, it must be energised the valve for minimum capacity for around 25 seconds before switching off the compressor. Moreover the valve (14) should be kept energised during the compressor standstill periods.

The starting and stopping procedure indicated in Picture 3-R has to be followed for all the screw compressors, both in the step and in the stepless version, as this avoids noisy stopping caused by temporary reverse rotation with high mass flow (see chapter EA-04: "Components").

	<p>Warning!</p> <p>If having to shutdown in an emergency, the compressor will stop at the current capacity step. In the stepless configuration then, before restarting the unit, make sure that the compressor is at the minimum capacity step.</p>
---	--

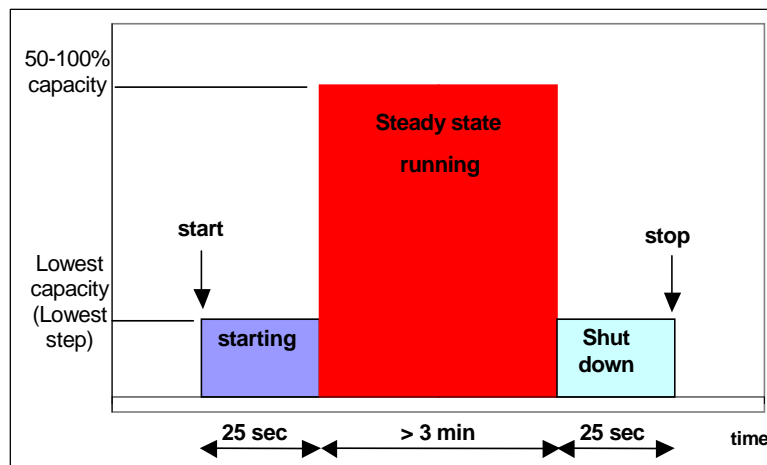

Picture 3-R: starting and stopping the compressor;

As regards the series 134-XS compressors, on the other hand, not having the slide valve and consequently not having to wait for the oil to be discharged from the control cylinder to return to in the minimum load position, simply start the compressor with both the solenoid valves 20 and 21 energised for around 25 sec.

3.4 Operating limits at part load

Operation at part load increases the discharge temperature (it is recommended not to exceed 110° C) and has a slightly lower efficiency than at full load.

In particular, the discharge temperature increases if:

- The condensing pressure increases;
- The evaporation pressure decreases;
- The temperature of the suction gas (superheat) increases.

To define the operating limits at part load, see chapter EA-10: “Application range”.

3.5 Managing the stepless partial load

The stepless capacity control system is suggested when it’s necessary to perform an high accuracy on managing the generated cooling capacity, whereas it proves to be not so efficient in such as cases where the inertia of the system is too high. In these cases the step capacity control is more suitable.

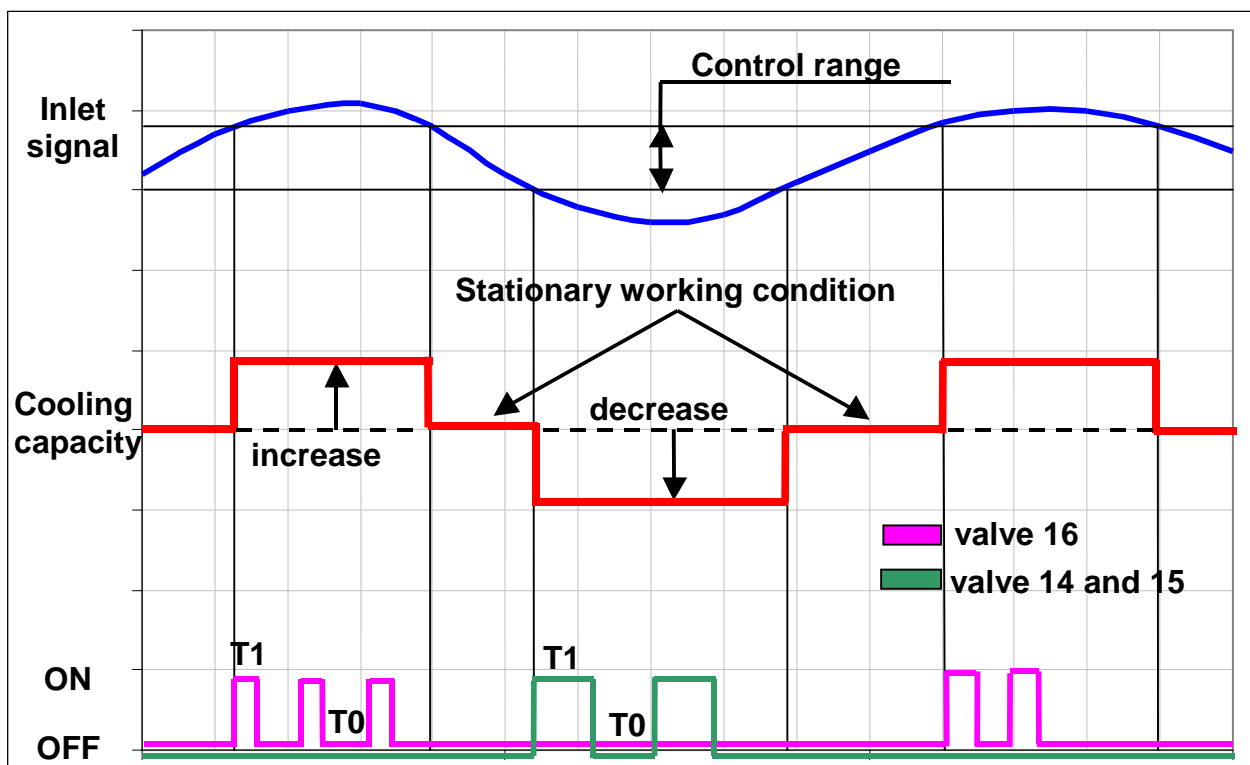

Picture 3-S: infinite capacity control logic;

With reference to Picture 3-S, the capacity delivered by the compressor is controlled by using a control device that, in response to a variation in the load required by the users, opens the solenoid valves (14), (15) and (16) described above. In particular, these valves are energised by pulse signals and, as regards the control device input signal, the parameter chosen should be sensitive to the variation in the load required by the users. For instance the suction pressure or evaporator air or water temperature can be used.

Picture 3-S shows the series of impulses that energise the valves (14), (15) and (16) and used to adapt the delivered mass to the required cooling capacity. You can note that when the value of the input variable does not move outside of the range of control (differential), the system does not react and the compressor operates in stationary conditions. The solenoid valves should be energised using brief impulses ($T1= 0.5-1$ sec). Usually, the energising period of solenoid valve (16) can be shorter than the energising period of solenoid valves (14 or 15). The series of impulses continues until the value of the control variable returns within the range of control (differential). The time interval between two impulses ($T0$) must be set to optimize the control, according to the inertia of the system.

	<p>Refcomp at any rate suggests:</p> <ul style="list-style-type: none">✓ not to operate with a capacity below 50% for longer than around 5 minutes, so as to avoid excessive overheating of the electric motor;✓ not to switch rapidly from full load conditions to minimum load, but rather to remain for a minimum time of 3 minutes at 50%. Otherwise liquid may enter the compressor causing damage;✓ if there is a continuous variation in the capacity of the compressor, even if there are not appreciable variations in the load required by the users, check and if necessary adjust the timers on the control device.
---	--