

---

*SRC-XS and SRC-S series compressors*

*ECONomizer*

*(SA-12-04-E)*

<b>12</b>	<b>ECONOMIZER</b>	<b>2</b>
12.1	OPERATING PRINCIPLE	2
12.2	COMPONENTS SELECTION	3
12.3	ADDITIONAL SUGGESTIONS	3
12.4	WORKING LIMITS	4

## 12 ECONomizer

### 12.1 Operating principle

The economizer, which is an external heat exchanger, sub-cools the liquid leaving the condenser so as to increase the efficiency of the refrigerant cycle. Indeed, with this sub-cooling process the mass flow, that is sent to the evaporator after the expansion, has a lower vapour rate than what would be the case in a normal refrigerating cycle. This entails an increase in the cooling capacity and just a small increase in the power input of the compressor for it has to process the additional mass flow of the economizer circuit. Then an increase in the coefficient of performance is achieved (see picture 12-A<sup>1</sup>).

Referring to the same picture, the ECONomizer heat exchanger sub-cools the liquid leaving the condenser with the heat transferred to a flow of refrigerant that is tapped from the liquid line and expanded in a thermostatic valve to the intermediate injection pressure. The superheated vapour leaving the ECO-exchanger is then injected onto the rotors through the economizer port in the compressor, where it mixes with the suction gas, already slightly compressed, coming from the evaporator. The expansion of the tapped liquid flow occurs in the thermostatic valve which, using the bulb located on the ECO-exchanger outlet, controls the correct degree of superheat.

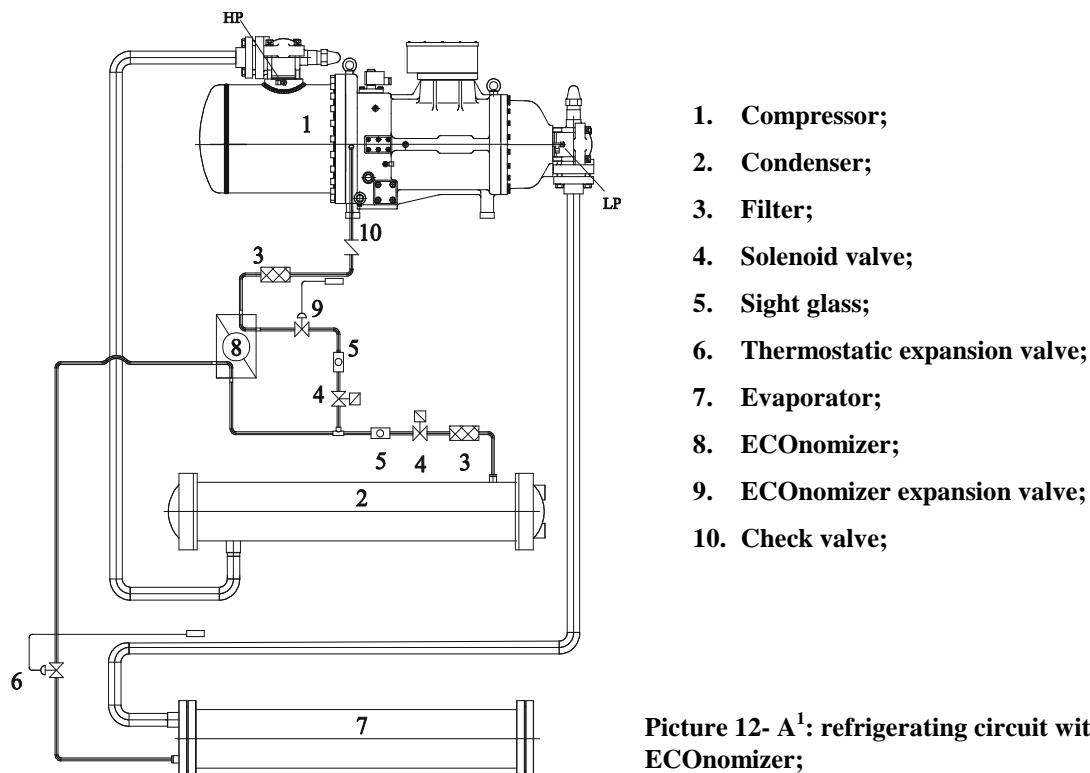

Picture 12- A<sup>1</sup>: refrigerating circuit with ECONomizer;

<sup>1</sup> This is simply a schematic drawing; refer to the drawing of each model of compressor for the position of the vapour injection port on the compressor (ECONomizer port).

**12.2 Components selection**

• **ECO-heat exchanger**

Shell and tube, coaxial tube and brazed plate heat exchangers can be used. The data for sizing the exchanger are given by the RefComp LEONARDO selection software; if this software is not available, please contact RefComp. To avoid injecting liquid onto the rotors, it is recommended to work with the superheat set to around 10 K.

**12.3 Additional suggestions**

The sub-coolers should be installed below the compressor in order to avoid possible backflows of oil or liquid refrigerant to the compressor during standstill periods. As the compressor may expel a certain quantity of oil through the economizer port when the operating conditions have not yet stabilised or alternatively when the sub-cooling circuit is disabled, the injection pipe should be fitted with an elbow as illustrated in picture 12-B<sup>1</sup>. The economizer port leads directly to the rotors, therefore a fine mesh filter (max 25 µm) should be installed. The diameter of the injection pipe should be selected according to Table A.

<b>SRC-XS</b>	<b>40</b>	<b>50</b>	<b>60</b>
<b>Diametro [mm]</b>	22		

<b>SRC-S</b>	<b>113</b>	<b>133</b>	<b>163</b>	<b>183</b>	<b>213</b>	<b>253</b>	<b>255</b>	<b>285</b>	<b>303</b>	<b>305</b>	<b>353</b>	<b>413</b>	<b>463</b>	<b>503</b>	<b>553</b>	<b>603</b>	<b>785</b>	<b>785</b>	<b>885</b>	<b>985</b>
<b>D[mm]</b>	22									28			42		28	42				

**Table A: economizer injection pipes diameters;**

The following kit must be used for connecting the ECONomizer to its port on the compressor:

- Models SRC-S-113/133/163/183/213: kit n° 303150;
  - Components: Injection fitting n° 517740
  - Teflon gasket n° 592360
  - Aluminium washer n° 613840
  - Cosval shut off valve n° 614475
  
- Models SRC-XS-40/50/60 and SRC-S-253/255/285/303/305: kit n° 303156;
  - Components: Injection fitting n° 517740
  - Teflon gasket n° 592360
  - Aluminium washer n° 613840
  - Cosval shut off valve n° 614484
  
- Models SRC-S-353/413/463: kit n° 303151;
  - Components: Flange connection n° 519085
  - oval flange gasket n° 591030
  - Teflon gasket n° 592360
  - Cosval shut off valve n° 614476

<sup>1</sup> This is simply a schematic drawing; refer to the drawing of each model of compressor for the position of the vapour injection port on the compressor (ECONomizer port).

- Models SRC-S-503/553/603: kit n° 303319;

Components: shut off valve	n° 500900
self-adhesive label for spare parts	n° 585600
kit assembly diagram	n° 585899
shut off valve gasket	n° 590790
shut off valve gasket int.	n° 591010
screw grower washer M12	n° 610960
screw 10.9 M12x80	n° 613520

- Models SRC-S-755: kit n° 303572;

Cmponents: Flange connection	n° 511620
Teflon gasket	n° 591020
Assembly scheme	n° 585920
Rotalock connection	n° 501480
Flange oval gasket	n° 591030

- Models SRC-S-785/885/985: kit n° 303883;

Cmponents: Flange connection	n° 511620
Teflon gasket	n° 591020
Rotalock connection	n° 614621
Flange oval gasket	n° 591030

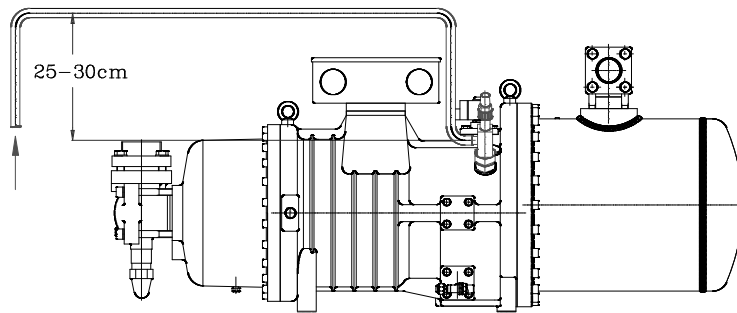

**Picture 12- B: Economizer line lay out;**

## 12.4 Working limits

Due to the compression of the additional mass flow (tapping of liquid leaving the condenser) and the consequent overloading of the motor, the operating limits with the economizer are partially more restricted than the standard conditions for the normal operation of the compressor (see chapter SA-10: "Application ranges").

For the models SRC-S-255/285/305 the ECO injection port towards the rotors is located on the slide valve. This way the ECO-circuit can be activated down to 50% load.

The remaining models of the SRC-S series and the SRC-XS-40/50/60 do not feature this special constructional solution and consequently the ECONomizer can only be used to increase the cooling capacity when operating at 100% load.



**Warning!**

- ✓ For what concerns the models SRC-S-255/285/305, the economiser use is allowed from 50% to 100% load;
- ✓ For the remaining models of the series SRC-S and for the SRC-XS compressor series, the sub-cooling circuit can be used only on full load conditions;
- ✓ During start up, the economiser circuit has to remain disconnected until the working conditions are not stable (the use of a timer to turn on the ECO is recommended).